

JPT-16-S

View without dust cap /
Ansicht ohne Staubschutzkappe
EJ-9-S

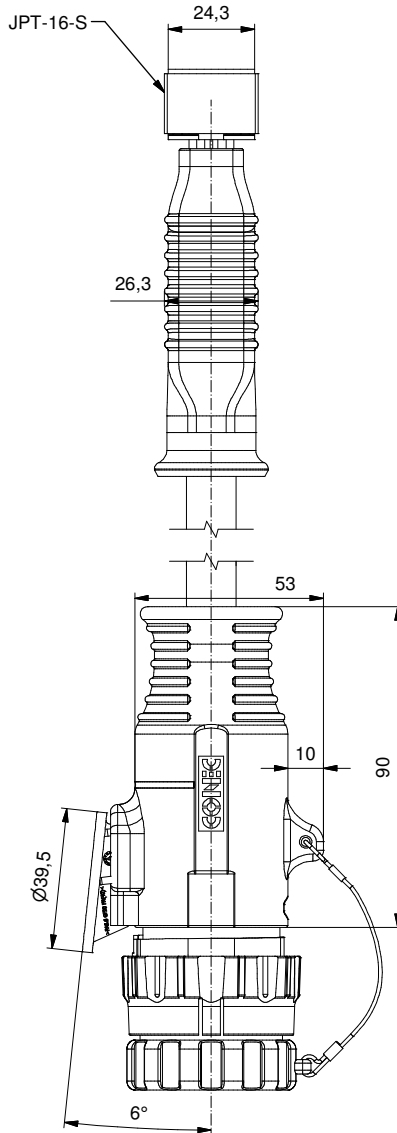
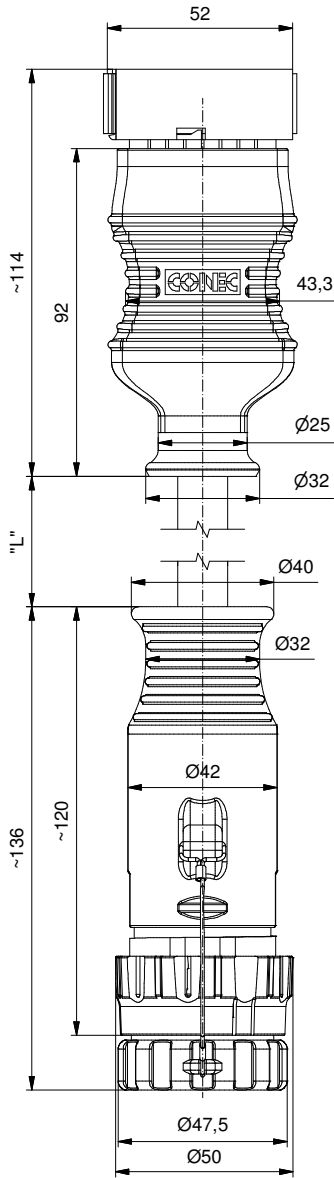
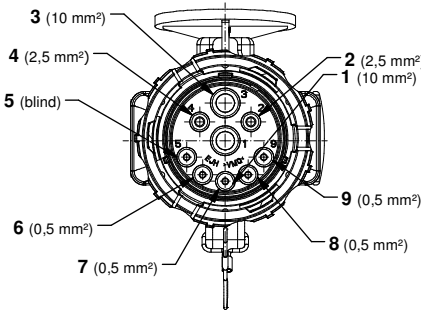
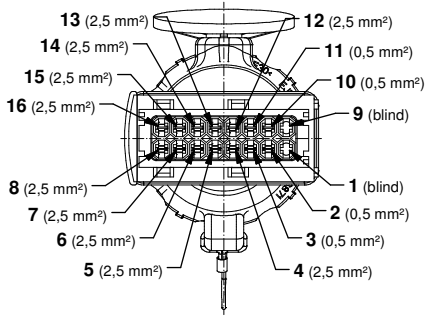

Technical specification:

Technische Daten:

Rated voltage / Strombelastbarkeit	12 V DC
Current rating / Strombelastbarkeit:	10 mm ² : 35 A at 40°C 2,5 mm ² : 15 A at 40°C 0,5 mm ² : 5 A at 40°C
Temperature range	
Connector / Umgebungstemperatur	
Stecker:	Isobus: -40°C ... +85°C JPT: -40°C ... +80°C
Temperature range	
wire / Umgebungstemperatur	fixed / -40°C ... +85°C
Leitung:	mov'd / -20°C ... +80°C
	fest / bewegt:
Degree of protection / Schutzart:	IP67, in mated condition / IP67, im gesteckten Zustand
Wire cross section / Anschlussquerschnitt:	2 x 10 mm ² 2 x 2,5 mm ² (Isobus) 4 x 0,5 mm ²
Wire cross section / Anschlussquerschnitt:	10 x 2,5 mm ² (JPT) 4 x 0,5 mm ²
Mating cycles / Steckzyklen:	>=100 (Isobus) >= 10 (JPT)
Housing / Gehäuse:	
Isobus:	Erich Jaeger Plug, black / schwarz
JPT 16pol.:	AMP JPT GEH KPL 16P, black / schwarz

Materials/ Werkstoffe:

Contact / Kontakt:	
Isobus:	CuZn
JPT:	CuFe 2 (2,5 mm ²) CuSn 4 (0,5 mm ²)
Contact plating / Kontaktoberfläche:	
Isobus:	Ni
JPT:	Sn
Contact carrier / Kontaktträger:	
Isobus:	Thermoplast
JPT:	PBT / ASA - GF 30
Overmolding / Umspritzung:	TPU, UL 94, V-0 black / schwarz
Sealing / Dichtung:	Silicon / Silikon
Landing plate / Landeplatte:	PA6.6 UL94 V-0, black/schwarz
Protection cap / Schutzkappe:	PA6.6 UL94 V-0, black/schwarz

Kontaktbelegung / Schematic diagram

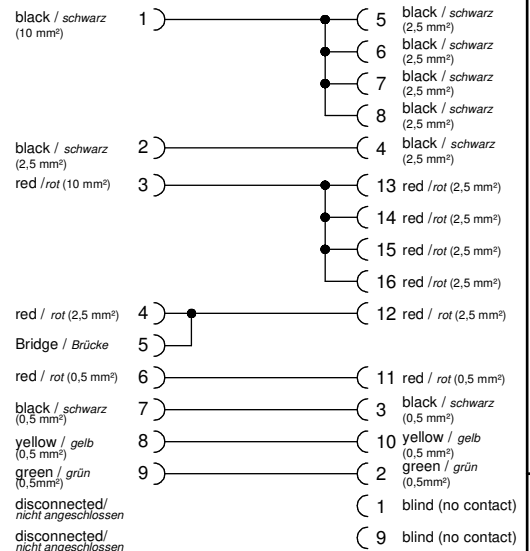

Isobus EJ

JPT-16-S

Part-no. / Art.-Nr.:	Description / Beschreibung:	Cable length "L" / Kabellänge "L":	Cable / Kabel:
55-10055	EJ-9-S-L1 - JPT-16-S/1000P/11m	11 m	PUR, Hybrid 2 x 10mm ² ; 2 x 2,5mm ² ; 4x0,5mm ² , Cable / Kabel: 781-BS0177 (b)
55-10082	EJ-9-S-L1 - JPT-16-S/1000P/14m	14 m	
55-xxxxx	EJ-9-S-L1 - JPT-16-S/1000P/...m	... m	

tolerance of cable / Kabeltoleranz:	L <= 12m: L + 120mm L > 12m: L + 1%	dim. in mm	Connecting cable Isobus 9pos. / 10 mm ²	
general tolerance / Allgemeintoleranz:	0 ± 0,50mm 0,0 ± 0,25mm 0,00 ± 0,10mm x ± 5°	Date/Datum: 22.02.2017 Name: Heinrich drawn/gez.: 22.02.2017 appd./gepr.: 22.02.2017 Strakerjahn	VB-Leitung Isobus 9 pol. / 10 mm ²	
Index: b Ä6824 18.08.17 K.H.	scale/Maßstab: 1 : 1,5 (1 : 2,5)	dwg no / Z.-nr.: 55K1A292		DIN-A3
Status: Freigegeben		CONEC®		1 / 1
RoHS compliant/konform				

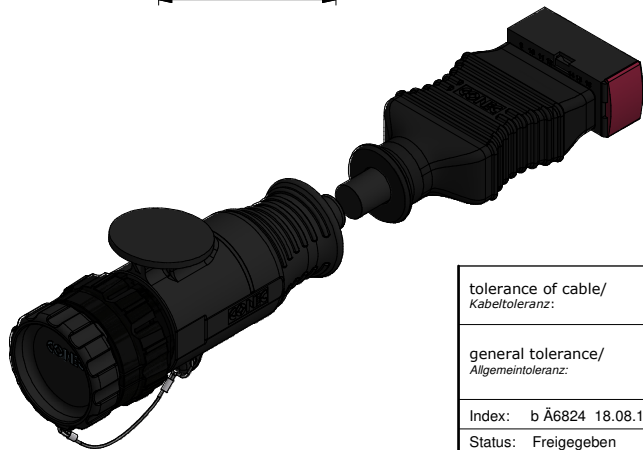

The reproduction, distribution and utilization of this document as well as the communication of its contents to third parties without express authorization is prohibited. Offenders will be held liable for the payment of damages. For further information on this subject, please contact your dealer or the manufacturer. © 2017 CONEC AG, Schwanau, Germany.